



INTEGRATED  
SYSTEMS  
DESIGN



# UltraStore™ ASRS

**Automated Storage  
and Retrieval Systems**

## UltraStore Mid-Load ASRS Provides Cost Effective Storage and Retrieval

The Mid-Load UltraStore™ Automated Storage and Retrieval System (ASRS) handles pallets, cartons, trays, totes and uniquely sized items for applications requiring quick deployment, lower acquisition cost and rapid return on investment (ROI).

The mid-load design is ideal for applications in which a mini or unit load system doesn't match the specific application or is too costly. Its flexible design, plus the use of off-the-shelf standard components, permits economical custom engineered solutions to meet most storage and retrieval requirements.

High density storage makes the most of the available footprint & maximizes vertical storage space while providing safer, more ergonomic working conditions.

**Perfect-Uptime™** option provides 100% accessibility to inventory even during preventive maintenance periods. Depending on the level of critical access required a manual or totally automated Perfect-Uptime solution can be up and running in minutes.

**Customizable Load Handler Design** allows the use of forks, conveyor decks or custom devices to be used depending upon the weight, size and physical characteristics of the stored items. One example, is our patented load handler for Investment Cast applications.

**Fast ROI** because of the cost effective operation of the UltraStore Mid-Load ASRS, ISD can often design a system that meets and exceeds throughput requirements while providing a lower acquisition cost. By reducing labor and wasted floor space, while increasing throughput and accuracy, the UltraStore Mid-Load ASRS offers a fast ROI.

**Made & Designed in the USA** means faster delivery times, no need for currency conversion, and non-proprietary components.

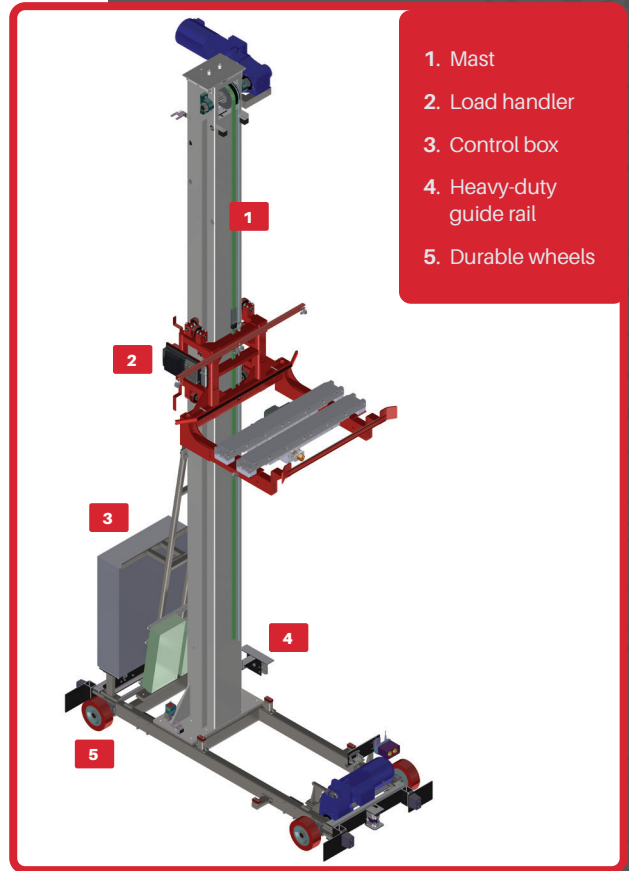

### Full Range of Storage & Retrieval Options

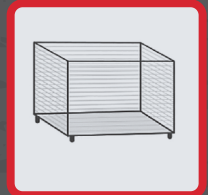
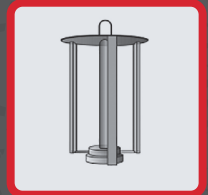
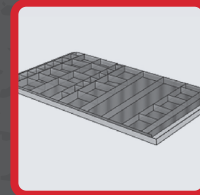
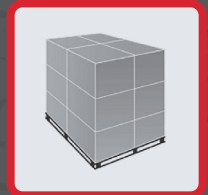
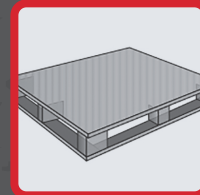

# Complete Automated Material Handling Solutions



## System Benefits

- Offsets labor by up to 2/3
- Up to 85% space savings
- Improves productivity & throughput
- Eliminates damaged & missing inventory
- Low cost of ownership
- Reduces travel between operations for improved order cycle time

## UltraStore Mid-Load ASRS Applications

- Assembly
- Queuing
- Buffering
- Sequencing
- High Density Storage
- Staging
- Order Picking
- Work-in-Progress

## Features

- > The Perfect-Uptime™ option for reliable access to inventory
- > Availability of off-the-shelf parts for added reliability
- > Ability to expand & move the system
- > Unique flexible design handles all types of loads
- > AGV, AGC & Conveyor interface for flexible solution handling
- > Reduces training costs with intuitive controls
- > Rapid delivery & deployment

## Industries

3PL

Aerospace

Alternative Energy

Appliance Manufacturing

Automotive Components

Automotive Tier 1&2 Suppliers

Chemical & Paint Packaging

Computer & Electronics

Consumer Goods

Distribution

E-Commerce

Food & Beverage

Furniture

Garments

Hardware

Health & Beauty Aids (HBA)

Investment Casting

Manufacturing

Medical Device

Pet Supplies

Petroleum Packaging

Pharmacy & Medical

Publishing

Refrigerated Warehouses

Retail

Sporting & Athletic Goods

Wholesale



# What Separates ISD From the Competition?

Integrated Systems Design (ISD) is a leading manufacturer and systems consultant, designer and integrator for manufacturing, warehousing, distribution, whole and retail organizations. ISD systems are renowned for their unparalleled value, reliability and ease of maintenance.

ISD solutions provide space savings, increased productivity, reduced labor, higher accuracy and system flexibility to change with the needs of the business. Utilizing proven technology and standard components provides cost effective solutions with minimum maintenance yielding a fast Return on Investment (ROI).

Sequencing of automotive assemblies for Tier 1 suppliers has been core to ISD and the UltraStore product line. With decades of knowledge and more installations than any other manufacturer, trust your business with the most experienced team in the industry.

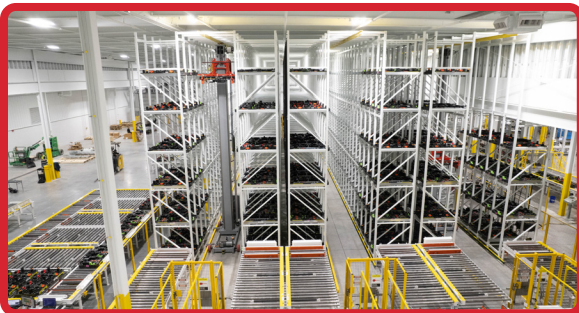

## ISD Guaranteed Performance Program

For organizations looking to guarantee their throughput, ROI and total system, ISD offers a Guaranteed Performance Program for all of its order picking, packing, shipping and assembly systems.

Ask your UltraProducts representative for more information.



**INTEGRATED SYSTEMS DESIGN**

Designed. Developed. Delivered. [isddd.com](http://isddd.com)

Phone: 248-668-8250 Fax: 248-668-8568